

## Shaft-Mounted Clutch-Brake

### LSCB-44

Nexen's through-shaft, air-to-spring clutch-brake is the ideal solution for repetitive start/stop conveying applications. Mounted on the roller shaft of an accumulating conveyor, LSCB clutch-brakes provide positive stopping and holding. Nexen's splined hub design assures full brake torque to the system. Both clutching and braking components utilize the same piston to eliminate simultaneous engagement. Because the clutch release springs also serve as the brake engagement force, the brake automatically engages as the clutch releases for fast, dependable stopping and holding. Combining simple design, outstanding performance and low cost, the LSCB-44 is the obvious choice for motion control on material handling conveyor systems.



- Clutch Torque: 238 Nm at 5.5 bar [2110 in-lb at 80 psi]
- Brake Torque: 6.3 Nm [56 in-lb] at zero air pressure
- Bore range: 12-32 mm [0.500-1.250 in]
- Single piston design eliminates possibility of clutch-brake overlap
- Brake engagement stops LSCB hub
- Variable mounting configurations: customer supplied sprocket or can be configured for sheave, plate or double-single sprocket or timing belt sprocket
- Open design for improved airflow and high heat dissipation
- Internal spline drive for trouble-free disengagement performance
- Shielded ball bearings standard for zero drag torque— shear modulus of bearing grease creates negligible drag torque (sealed bearings also available)
- No rotary air union required
- Field repairable o-rings, facings and springs
- Through-shaft design with three set screws for easy mounting

# LSCB-44, Approximate Dimensions

Units can be configured with plate or double-single sprocket, timing belt sprocket, or v-belt sheave. Please consult factory for details.

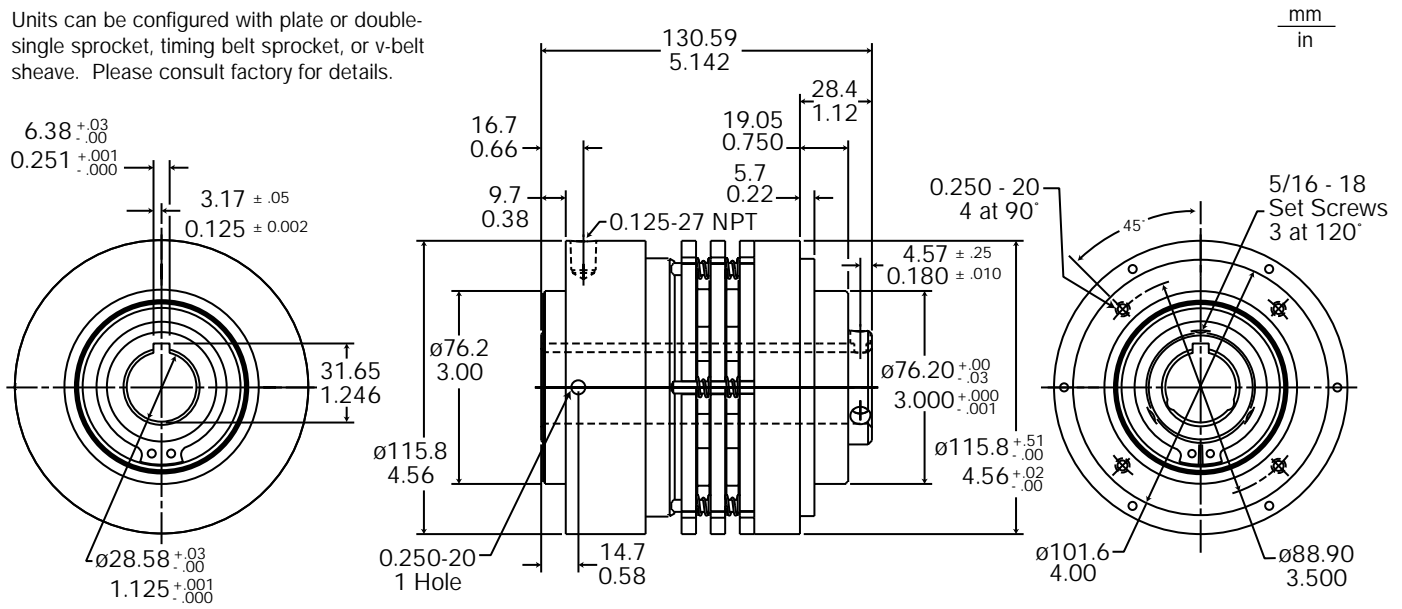

## Specifications

Model	Product Number	Bore Range mm [in]	Clutch Torque at 80psi Nm [in-lb]	Brake Torque at 0 psi Nm [in-lb]	Inertia <sup>1</sup> rotating with drive kg-m <sup>2</sup> [lb-in <sup>2</sup> ]	Inertia <sup>1</sup> rotating with shaft kg-m <sup>2</sup> [lb-in <sup>2</sup> ]	Shipping Weight kg [lbs]
LSCB-44	923570	28.6 [1.125]	238 [2110]	6.3 [56]	0.00337 [11.51]	0.000889 [3.03]	3.6 [8]
LSCB-44	Consult Factory	12-32 [0.500-1.250]	238 [2110]	6.3 [56]	0.00337 [11.51]	0.000889 [3.03]	3.6 [8]

<sup>1</sup> This is a calculated value.

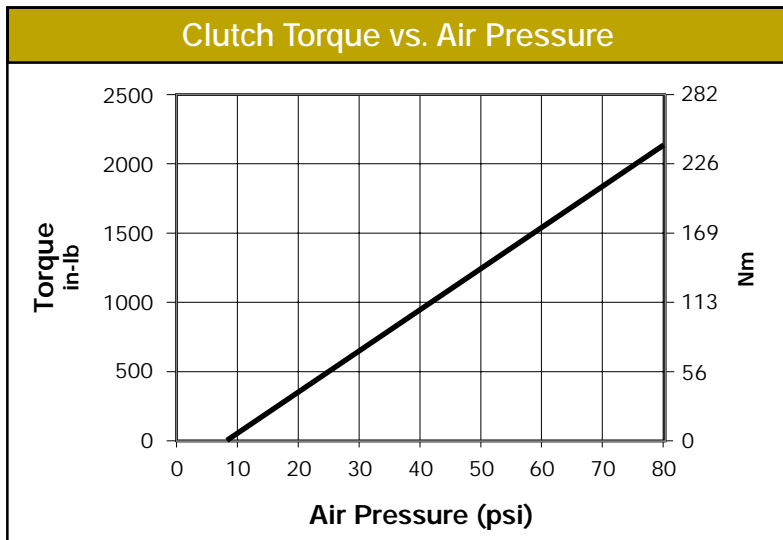

**Spring-Set Brake Torque**

6.33 Nm [56 in-lb]

SINGLE - TYPE 'A' SPROCKET SIZES (using standard single strand roller chain)						
Pilot Diameter	Sprocket Number					
	25	35	40-41	50	60	80
H	Minimum # of Teeth					
76.2 mm [3.000 in]	60	40	31	25	22	--

In accordance with Nexen's established policy of constant product improvement, the specifications contained in this document are subject to change without notice. Technical data listed in this document are based on the latest information available at the time of printing and are also subject to change without notice. For current information, please consult: [www.nexengroup.com](http://www.nexengroup.com)

**nexen**

Nexen Group, Inc.  
560 Oak Grove Parkway  
Vadnais Heights, MN 55127

800.843.7445  
Fax: 651.286.1099  
[www.nexengroup.com](http://www.nexengroup.com)

ISO 9001 Certified

©2002 Nexen Group, Inc.  
21147-A-0702